

## ELEMENTS

### TOP CONSTRUCTION

- SUBSTRATE:** Standard table tops are constructed with 1-1/8" M3 Industrial Grade 47# density particle board. NAUF and FSC® options are available.
- DECORATIVE SURFACE:** Constructed with HPL (high pressure laminate) which meets or exceeds performance requirements of NEMA LD 3
- BACKER:** Backer matched grade of laminate for balanced construction. Meets or exceeds performance requirements of NEMA LD 3
- ADHESIVE:** GREENGUARD® Certified Water-Based PVA glue
- EDGING:** See edge treatment guide for more information on edging options [www.surfaceworks.us/Edges.html](http://www.surfaceworks.us/Edges.html)
- MOUNTING:** Table tops are predrilled for easy installation & alignment.

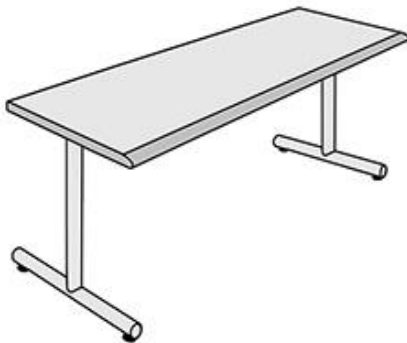

### BASE CONSTRUCTION

- DESCRIPTION:** All welded base for maximum strength and durability
- MATERIAL:** Tubing: Column - 2"dia. 14-gauge steel. Feet - 2"dia. 14-gauge steel
- FINISH:** Powder coated with scuff resistant environmentally friendly powder
- HEIGHT:** 27.75"
- FOOT TYPE (STANDARD):** 1-3/8" diameter and 5/16"-18 stud w/ nylon foot
- FOOT TYPE (OPTIONAL):** Casters- 2" dual wheel locking
- MOUNTING PLATE:** 13/16"x 5"x 8" steel

## ELEMENTS ULTRA FLIP

### TOP CONSTRUCTION

- SUBSTRATE:** Standard table tops are constructed with 1-1/8" M3 Industrial Grade 47# density particle board. NAUF and FSC options are available.
- DECORATIVE SURFACE:** Constructed with HPL (high pressure laminate) which meets or exceeds performance requirements of NEMA LD 3
- BACKER:** Backer matched grade of laminate for balanced construction. Meets or exceeds performance requirements of NEMA LD 3
- ADHESIVE:** GREENGUARD® Certified Water-Based PVA glue
- EDGING:** See edge treatment guide for more information on edging options [www.surfaceworks.us/Edges.html](http://www.surfaceworks.us/Edges.html)
- MOUNTING:** Table tops are predrilled for easy installation & alignment.

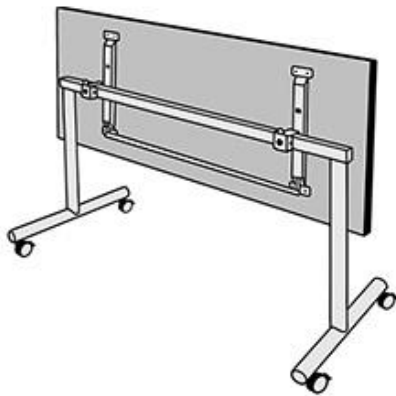

### BASE CONSTRUCTION

- DESCRIPTION:** Welded/bolted base for maximum strength and durability with positive-locking flip mechanism
- MATERIAL:** Tubing: Column - 2" dia. 14-gauge steel. Feet - 2" dia. 14-gauge steel
- FINISH:** Powder coated with scuff resistant environmentally friendly powder
- HEIGHT:** 27.75"
- FOOT TYPE (STANDARD):** Casters: 2" Twin Wheel Locking.
- MOUNTING PLATE:** Ultra Flip Mechanism

## ELEMENTS FOLDING

### TOP CONSTRUCTION

- SUBSTRATE:** Standard table tops are constructed with 1-1/8" M3 Industrial Grade 47# density particle board. NAUF and FSC options are available.
- DECORATIVE SURFACE:** Constructed with HPL (high pressure laminate) which meets or exceeds performance requirements of NEMA LD 3
- BACKER:** Backer matched grade of laminate for balanced construction. Meets or exceeds performance requirements of NEMA LD 3
- ADHESIVE:** GREENGUARD® Certified Water-Based PVA glue
- EDGING:** See edge treatment guide for more information on edging options [www.surfaceworks.us/Edges.html](http://www.surfaceworks.us/Edges.html)
- MOUNTING:** Table tops are predrilled for easy installation & alignment.



### BASE CONSTRUCTION

- DESCRIPTION:** Welded/bolted base for strength and durability with integrated folding mechanism
- MATERIAL:** 14 gauge, 2" diameter tubular steel T-leg with welded end caps
- FINISH:** Powder coated with scuff resistant environmentally friendly powder
- HEIGHT:** 27.75"
- FOOT TYPE (STANDARD):** 1-3/8" diameter and 5/16"-18 stud w/ nylon foot
- FOOT TYPE (OPTIONAL):** Casters- 2" dual wheel locking
- MOUNTING PLATE:** Molded plastic with steel spring clip. Legs lock in at both opened and closed position.